

MODEL NUMBER
ZR84KC/KCE
ZR94KC/KCE
ZP90KCE

SPECIFICATIONS	
ES NO.	DESCRIPTION
ES92-155	CONVERSION-METRIC

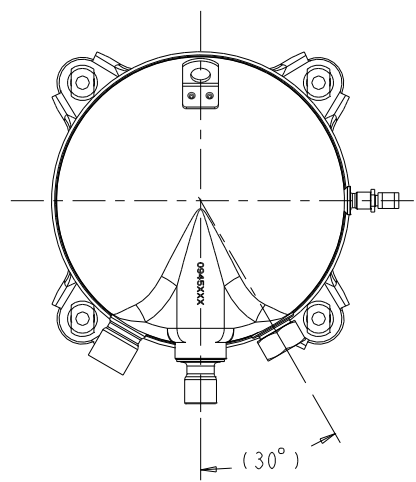

SIGHTGLASS LAYOUT
T-BOX REMOVED

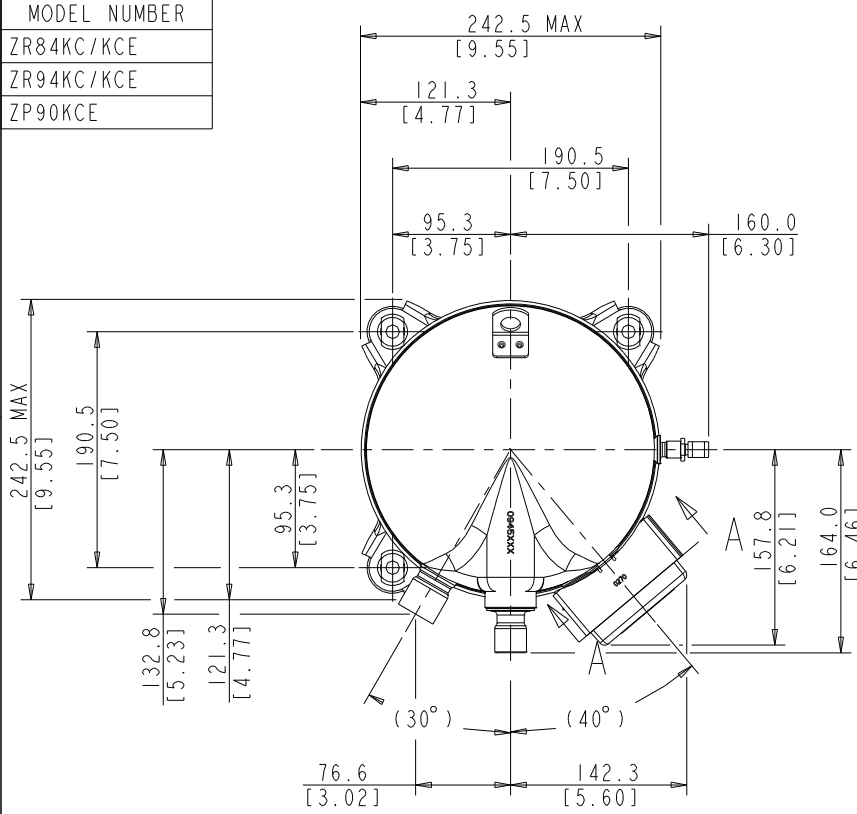
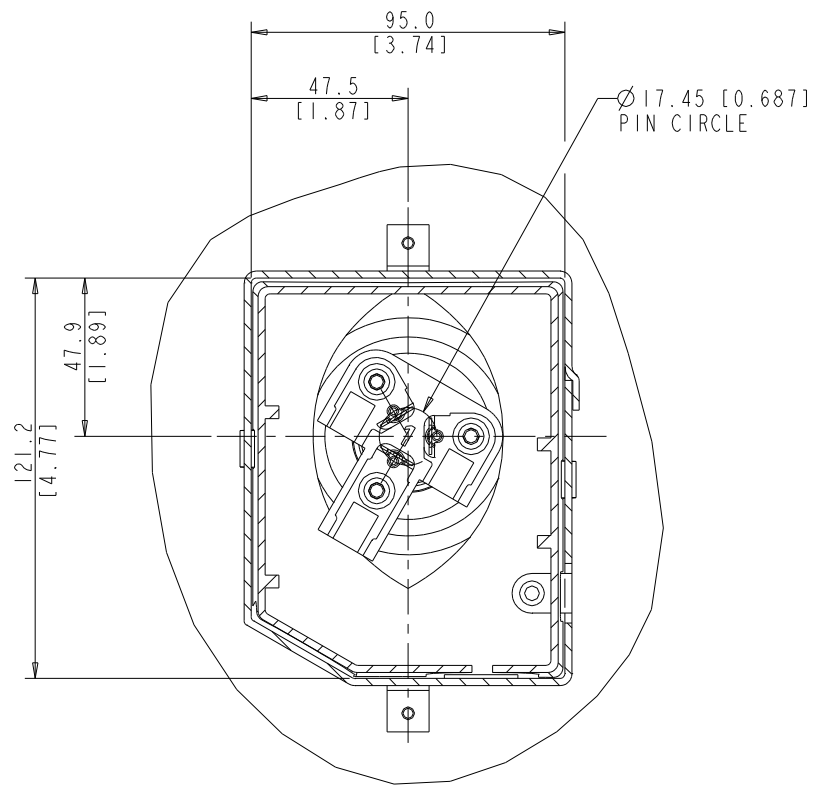

T-BOX LAYOUT
STANDARD
SECTION A-A
SCALE 1:1

- NOTES:
- ① ALL TOLERANCES ± 1.5 [0.06] UNLESS OTHERWISE SPECIFIED. DUE TO ACCUMULATED ASSEMBLY TOLERANCES THE LISTED COMPONENTS MAY VARY FROM THE MOUNTING HOLES AS TABULATED.
 - ② MOUNTING KIT: 527-0116-00
 - ③ TUBE ENDS MUST BE PLUGGED.
 - ③ \diamond SUCTION FITTING ± 3.0 [0.12]
 - ③ \diamond DISCHARGE FITTING ± 3.0 [0.12]

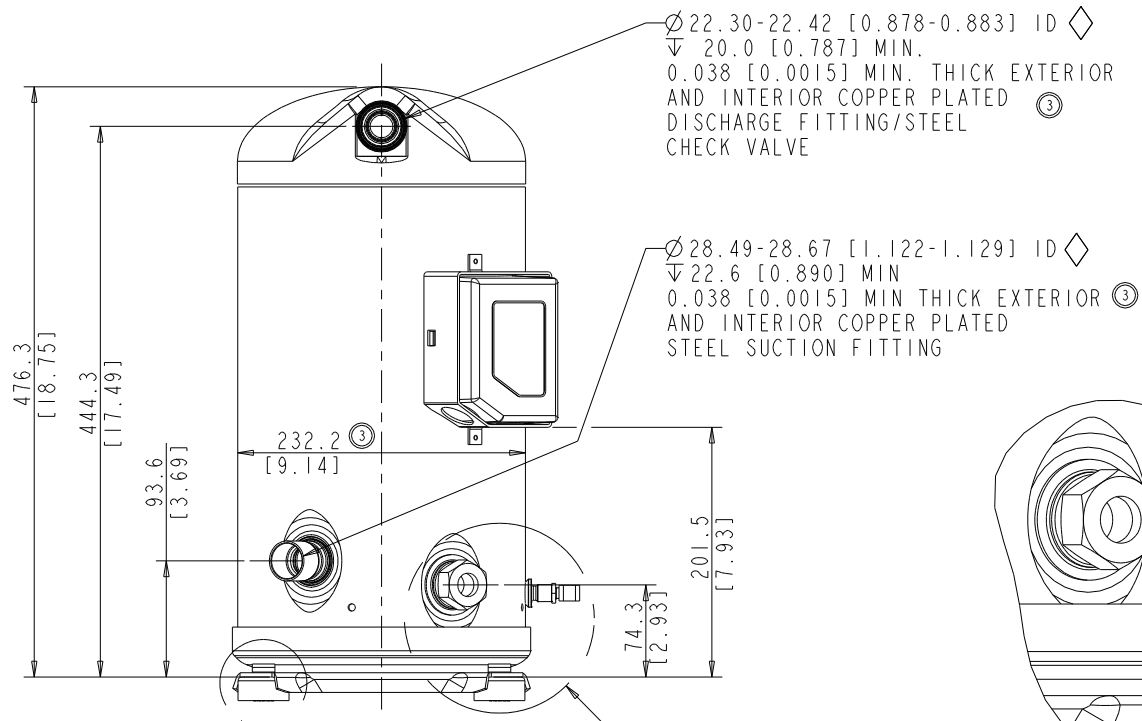
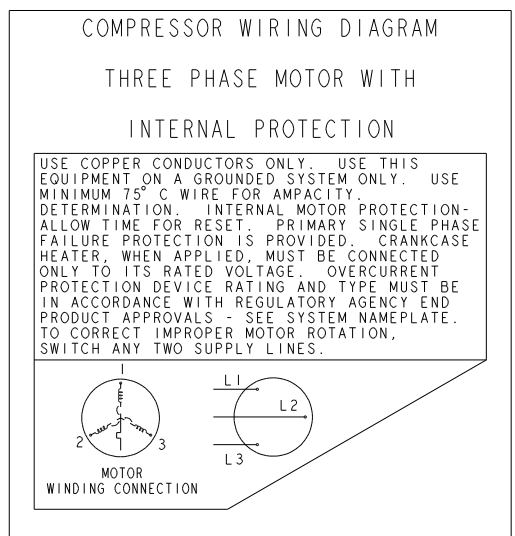

SEE DETAIL FOOT

SEE DETAIL VALVE

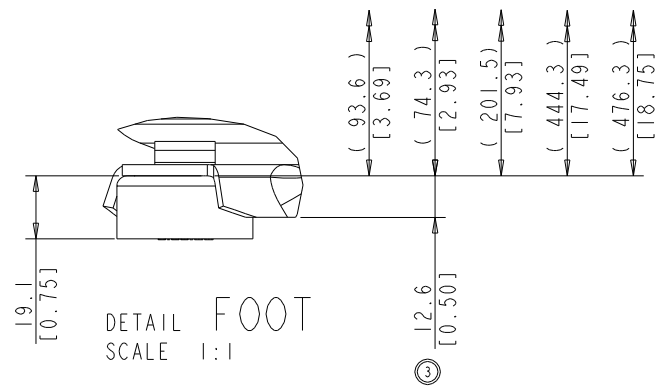

DETAIL FOOT
SCALE 1:1

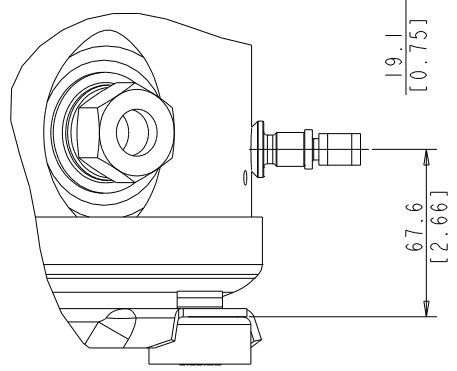

DETAIL VALVE
SCALE 3:4

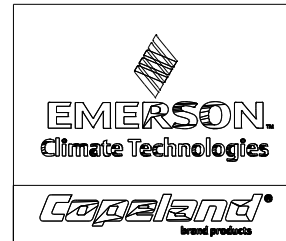

INTERPRET PER ASME Y14.5M-1994 AND EMERSON CLIMATE TECHNOLOGIES, INC. DESIGN STANDARDS DS2002 DO NOT SCALE DRAWING

THIRD ANGLE PROJECTION

CRITICAL PRODUCT CHARACTERISTIC

UNLESS OTHERWISE SPECIFIED DIMENSIONS ARE MILLIMETER OR (INCH)

TOLERANCES:
1-PLACE \pm N/A
2-PLACE \pm N/A
ANGULAR \pm N/A

ECN000821	3	REVISED AND REDRAWN	12-04-07	PBM	NJG	KJR
32-0303-054	0	RELEASED	08-24-05	PNA	CWK	RST
ENG NOTICE NO.	REV.NO.	REVISIONS	DATE	BY	CHKD	APPR
15						
CONFIDENTIALITY NOTICE						
THIS DRAWING AND INFORMATION CONTAINED HEREIN ARE THE EXCLUSIVE PROPERTY OF EMERSON CLIMATE TECHNOLOGIES, INC. AND SHALL BE RETURNED UPON DEMAND AND SHALL NOT BE REPRODUCED, IN WHOLE OR IN PART, DISCLOSED TO ANYONE ELSE OR USED, WITHOUT THE WRITTEN CONSENT OF EMERSON CLIMATE TECHNOLOGIES, INC.						
MATERIAL SPECIFICATION			DRAWN BY		SUPERSEDES DWG. NO. / REV. NO.	
N/A			PBM		497-0489-00 / 2	
			DATE		SCALE	
			12-04-07		3:8	
			DATE FORMAT:		MM-DD-YY	
TITLE			DRAWING NUMBER		SHEET 1 OF 1	
REF DWG-WELD COMP ASM-SERVICE			497-0489-00		4	
			SIZE			