

SPECIFICATIONS	
ES NO.	DESCRIPTION
ES92-155	CONVERSION-METRIC

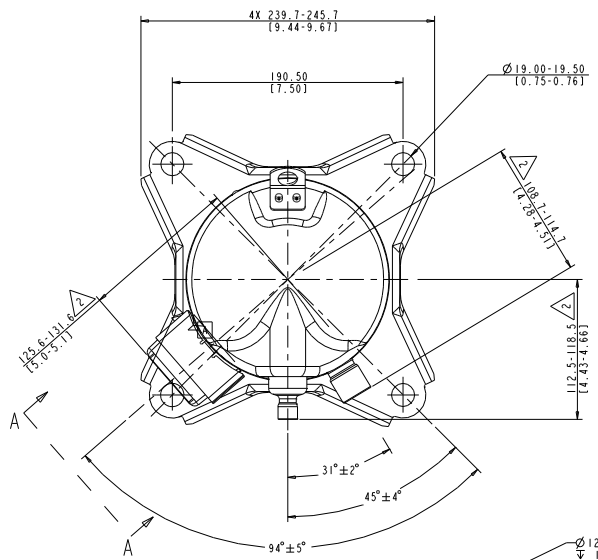

MODEL NUMBER
ZRS4KS-TF5, TF7, TFD ZRS4KSE-TF5, TFD
ZRS7KS-TF5, TF7, TFD ZRS7KSE-TF5, TFD
ZR61KS-TF5, TF7, TFD ZR61KSE-TF5, TFD ZR61KSE-TFM

Ø 12.78-12.90 (0.503-0.508) I.D.
 ± 0.001 (0.394) MIN. 0.038 (0.0015) MIN THICK EXTERIOR
 AND 0.038 (0.0015) MIN THICK INTERIOR COPPER PLATED STEEL
 DISCHARGE FITTING.

Ø 22.30-22.48 (0.878-0.885) I.D.
 ± 0.004 (0.803) MIN. 0.038 (0.0015) MIN THICK EXTERIOR
 AND 0.038 (0.0015) MIN THICK INTERIOR COPPER PLATED STEEL
 SUCTION FITTING.

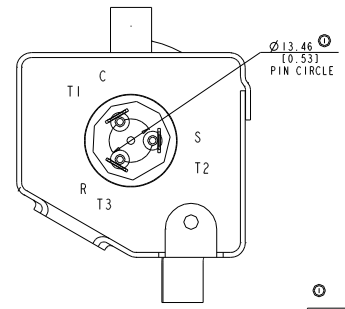

VIEW A-A
 SCALE 2:1

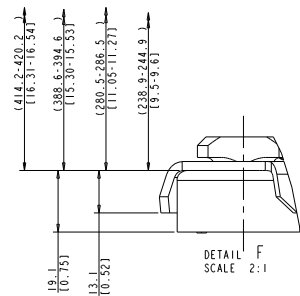
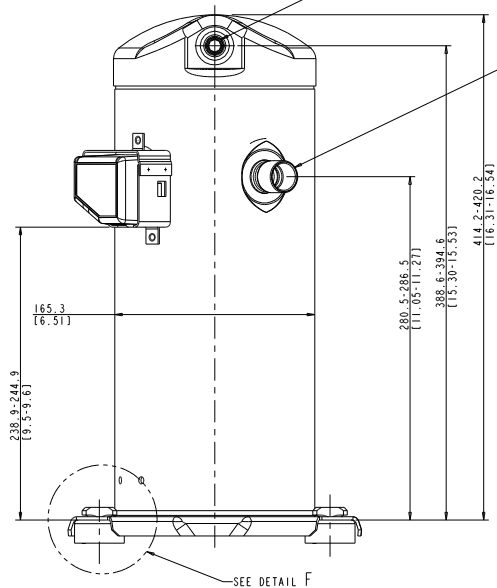

DETAIL F
 SCALE 2:1

NOTES:

- ALL DIMENSIONS IN MILLIMETERS AND DEGREES. (DIMENSIONS IN INCHES).
- ALL TOLERANCES ± 1.5 (0.06) UNLESS OTHERWISE SPECIFIED. THE SUCTION TUBE, DISCHARGE TUBE AND CIRCLE FENCE RADIAL DIMENSIONS ARE TO BE GAUGED FROM THE CENTER OF THE MOUNTING HOLE PATTERN.
- MOUNTING KIT:

GROMMET DUROMETER	4 FOOT KIT
35-45	527-0116-00
- TUBE ENDS MUST BE PLUGGED.

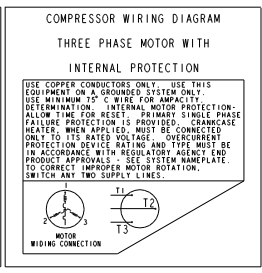
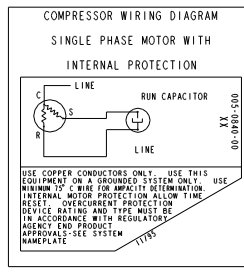

ECN000176	1	UPDATE	03-21-01	MT	DL	MC
ECN000176	0	RELEASED	11-21-96	MT <th>DL</th> <th>MC</th>	DL	MC

REV	DATE	BY	CHKD	APPD
1	03-21-01	MT	DL	MC

DATE	SCALE	DATE FORMAT	SHEET 1 OF 1
11-21-96	3:4	MM-DD-YY	1

DATE	SCALE	DATE FORMAT	SHEET 1 OF 1
11-21-96	3:4	MM-DD-YY	1

DATE	SCALE	DATE FORMAT	SHEET 1 OF 1
11-21-96	3:4	MM-DD-YY	1

DATE	SCALE	DATE FORMAT	SHEET 1 OF 1
11-21-96	3:4	MM-DD-YY	1

EMERSON Climate Technologies
 Copeland

COPYRIGHT EMERSON CLIMATE TECHNOLOGIES, INC. - CONFIDENTIAL